

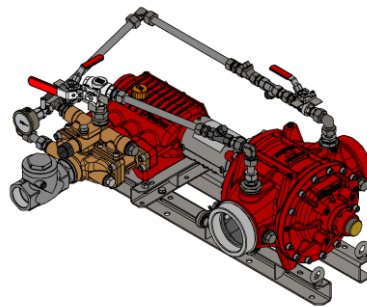



■ DATA SHEET PROPORTIONER FD2000 GEN III FOR STATIONARY EXTINGUISHING SYSTEMS.

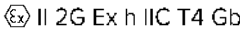

■ 1. TECHNICAL DATA.

Type	FD2000/0,5-S	FD2000/1-S	FD2000/3-S	FD2000/3/3-S
Proportioning rate	0.5 %	1 %	3 %	3% + 3% = 6%
Approvals	FM ²⁾	 FM Approval PR452158		–
	VdS ²⁾	–	 G420028	–
Flow directions of water motor	Horizontal: "left → right" or "right → left"			
	Vertical: "top → bottom" or "bottom → top"			
Min. water flow rate ¹⁾	180 l/min	180 l/min	200 l/min	250 l/min
Min. water flow rate FM	–	270 l/min	280 l/min	–
Max. water flow rate	2000 l/min			
Operating temperature ³⁾	5° C – 50° C (standard version)			
	5° C – 80° C (High-Temp version) ^{x)}			
Storage temperature	-20° C – 80° C			
Operating pressure	5 – 16 bar			
Weight ⁴⁾				
Freshwater version	59 kg	60 kg	86 kg	115 kg
Seawater version ^{x)}	104 kg	105 kg	131 kg	160 kg
ATEX classification ^{x)} for +5 °C ≤ T _a ≤ +60 °C	 			

1) The nominal proportioning rate is achieved when reaching the specified minimum figure. Indication for proportioning of fluid Newtonian foam agents at operating pressure of 5 bar. For more detailed information, refer to page 2, item 3. "Minimum water flow rate".

2) For information regarding FM Approved data, please refer to www.approvalguide.com. For VdS Approval conditions, see VdS Certificate G420028.

3) Operating temp. is the max. ambient and medium (foam and extinguishing water) temperature. Max. foam agent temp. is generally limited to 50 °C.

4) Weight indications are based upon the standard version in dry condition. Special versions will differ.

X) Optional equipment.



Valid for selected product types.



VdS Approval for FD2000/3-S



www.firedos.com

■ 2. PRESSURE LOSS.

Indication valid for operating pressure of 10 bar. For more information on different system conditions or proportioning rates, please contact us.

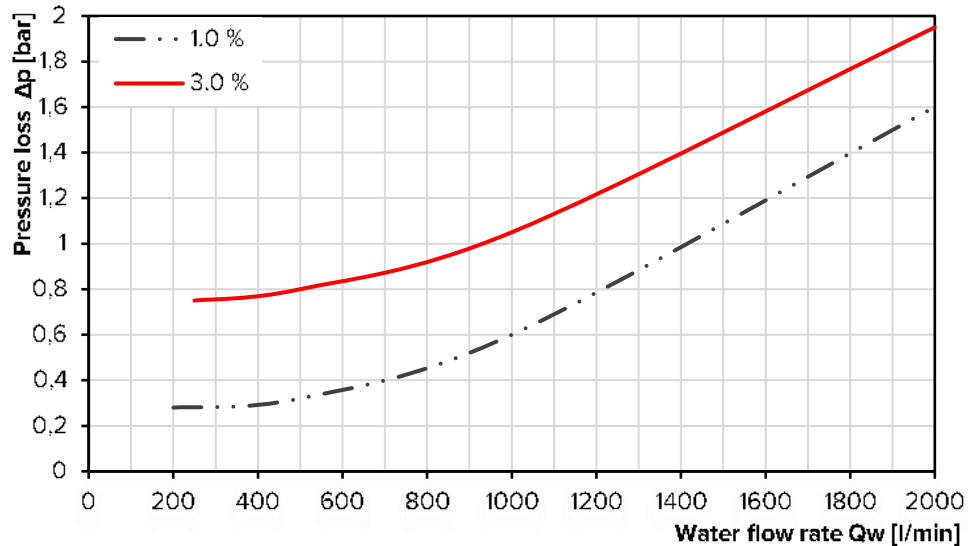

■ 3. MINIMUM WATER FLOW RATE.

The following diagrams show the effect of the operating pressure and foam agent viscosity on the minimum water flow rate (valid for viscosities in the graph at para. 4).

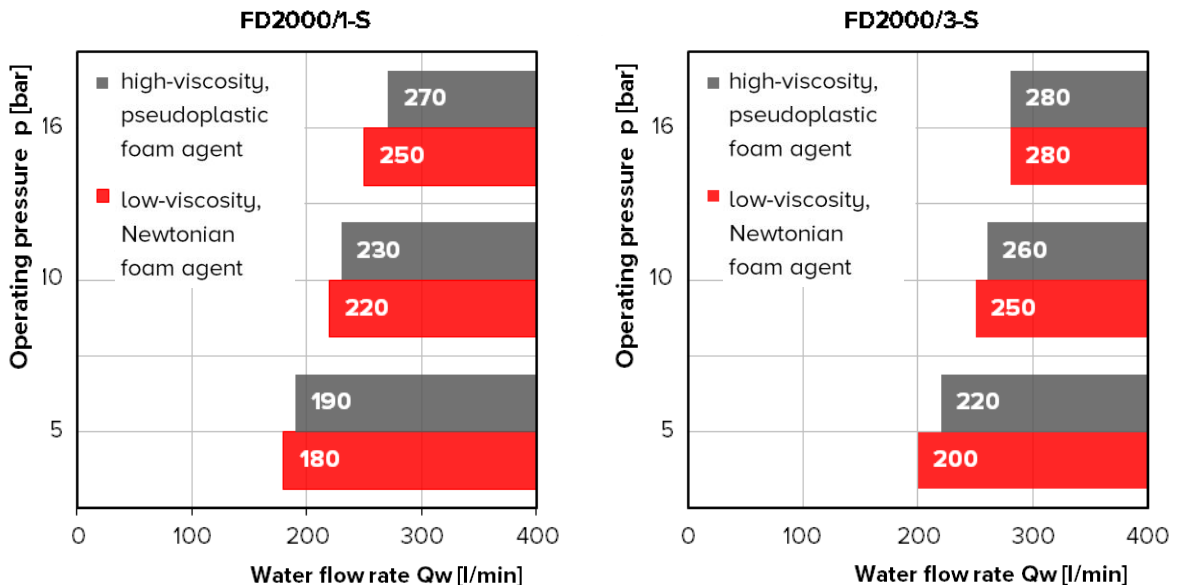

Comment:

The values can be reduced to approx. 35% by an optional flow reduction. The values increase by approx. 40% in the high-temp version. For values at other proportioning rates, please contact us.

4. FOAM AGENT VISCOSITY.

FireDos proportioners are suitable for all foam agents available on the market. For reference regarding units with an FM Approval, please find the corresponding/associated range of dynamic viscosity below (www.approvalguide.com). Contact us if the dynamic viscosity of your foam agent is higher than the values in the diagram. **Do not hesitate to request our support for the correct dimensioning of your suction line.**

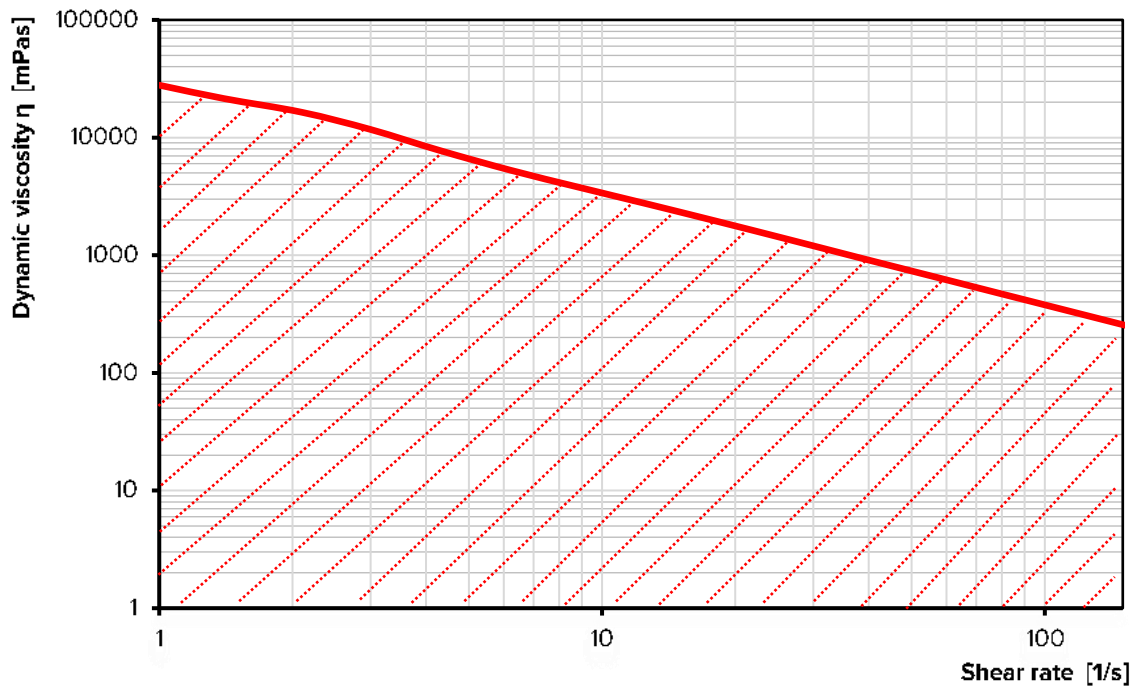

5. MATERIALS.

	Freshwater version	Seawater version
Water motor⁴⁾	Cast Aluminium G-AlSi7Mg HC-coated, AlMgSi1 HC-PTFE-coated, stainless steel 316 / 316Ti, POM, PVDF, NBR, FKM	Cast Bronze G-CuSn10, stainless steel 316 / 316Ti, Aluminium-Bronze CuAl10Fe5Ni5-C-GC, POM, PVDF, NBR, FKM
Proportioning pump⁴⁾	Stainless steel 316 / SS316Ti / 318 LN, POM, FKM, Aluminium oxide ceramic Al ₂ O ₃ , Aluminium-Bronze CuAl10Ni5Fe5-C-GC	
Pipework⁴⁾	Stainless steel 316 / CF8M / SS316Ti, PTFE, FKM	
Support frame	Stainless steel 304 / 316	

⁴⁾ media-exposed materials

6. FLOW DIAGRAM.

Proportioning rate 0.5% / 1% / 3%

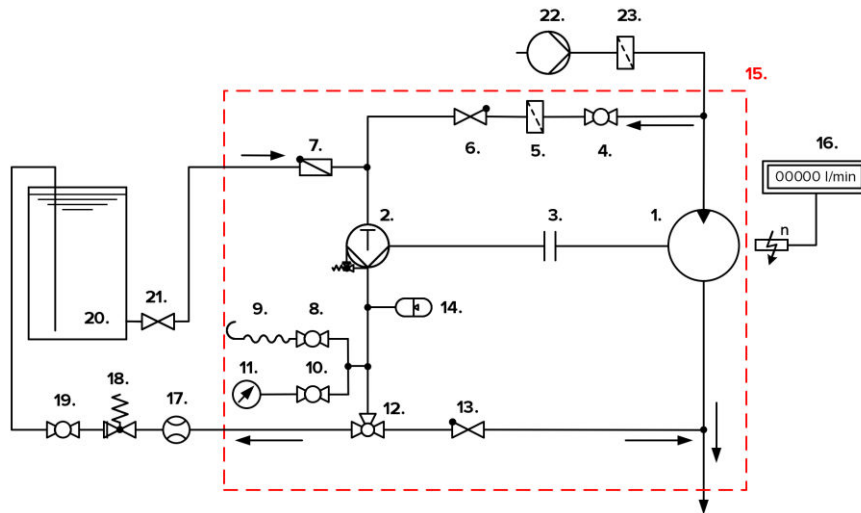

Proportioning rate 3% + 3% = 6%

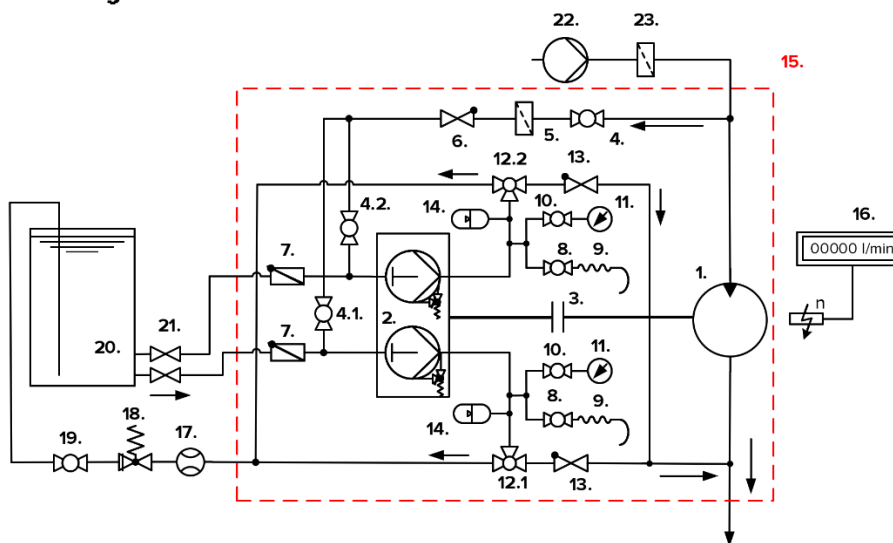

- | | |
|--|---|
| 1. Water motor | 12.1 "Returning/Proportioning" pump head I |
| 2. Proportioning pump | 12.2 "Returning/Proportioning" pump head II |
| 3. Coupling | 13. Check valve in the proportioning line |
| 4. 2-way ball valve "Flushing/Priming" | 14. Pulsation damper ¹⁾ |
| 4.1 "Flushing/Priming" pump head I | 15. Standard scope of supply of FireDos proportioner |
| 4.2 "Flushing/Priming" pump head II | 16. Revolution counter with flow rate display ^{*)} |
| 5. Filter in the flushing line | 17. Flow meter for return line ^{*)} |
| 6. Check valve in the flushing line | 18. Pressure sustaining valve for return ^{*)} |
| 7. Non-return flap in the suction line | 19. 2-way ball valve in return line ^{*)} |
| 8. Air bleed valve | 20. Foam agent supply |
| 9. Air bleed hose | 21. Shut-off valve in the suction line |
| 10. Shut-off valve pressure gauge | 22. Extinguishing water supply |
| 11. Pressure gauge | 23. Water filter |
| 12. 3-way ball valve "Returning/Proportioning" | |

X) Special version y) not applicable

7. EXAMPLE FIGURE / DIMENSIONS.

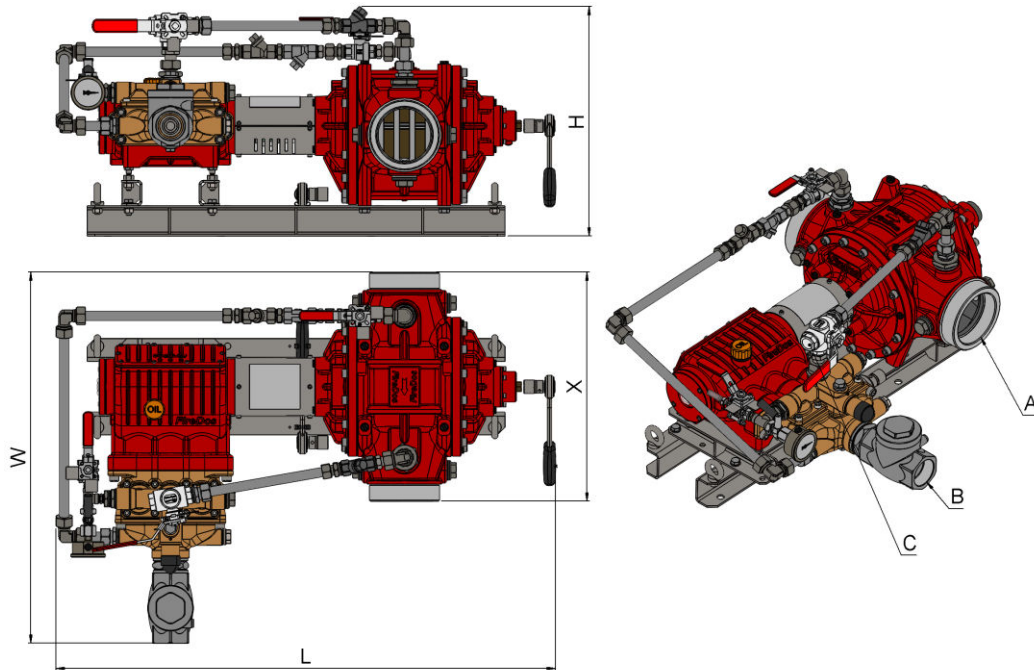

Type	FD2000/0,5-S	FD2000/1-S	FD2000/3-S	FD2000/3/3-S
Proportioning rate	0.5 %	1 %	3 %	3% + 3% = 6%
Connection water motor A	Optionally: 4" MT BSP, 3" FT BSP (Standard) Flange DIN EN 1092-1, DN100 PN16 RF Flange ASME B16.5, 4" Class 150 RF			
Installation length water motor X ⁵⁾	452 mm			
Connection suction line B	1.1/4" MT BSP 1.1/4" MT NPT ^{X)}	1.1/4" FT BSP 1.1/4" MT NPT ^{X)}	2" FT BSP 2" MT NPT ^{X)}	2x 2" MT BSP 2x 2" MT NPT ^{X)}
Connection return line C	1/2" FT BSP 1/2" MT NPT ^{X)}	3/4" FT BSP 3/4" MT NPT ^{X)}	1" FT BSP 1" MT NPT ^{X)}	2x 1" FT BSP 2x 1" MT NPT ^{X)}
Length L ⁵⁾	825 mm	900 mm	985 mm	985 mm
Width W ⁵⁾	503 mm	605 mm	740 mm	750 mm
Height H ⁵⁾	425 mm	445 mm	480 mm	570 mm

All figures are approximate only and depend on the particular version/equipment options.

X) Special version.

5) Further accessories to the proportioner may require more installation space.

Please allow sufficient accessibility of the proportioner for maintenance work. For assistance to ensure sufficient accessibility, please refer to our planning manual for proportioners.

8. MANUFACTURER.

FireDos GmbH, Auf der Kaulbahn 6, 61200 Woelfersheim, Germany
Phone +49 (0) 6036 9796-0, Email: info@firedos.de

We reserve the right to make modifications at any time.