

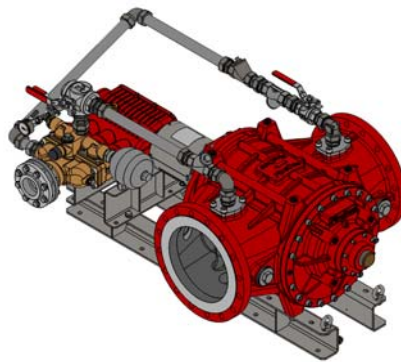

■ DATA SHEET PROPORTIONER FD20000 GEN III FOR STATIONARY EXTINGUISHING SYSTEMS.



■ 1. TECHNICAL DATA.

Type	FD20000/0,5-S	FD20000/1-S	FD20000/3-S	FD20000/3/3-S
Proportioning rate	0.5 %	1 %	3 %	3% + 3% = 6%
Approvals	–	 FM Approval PR452158 ²⁾		–
Flow directions of water motor	Horizontal: “left → right” or “right → left”			
	Vertical: “top → bottom” or “bottom → top”			
Min. water flow rate ¹⁾	750 l/min	750 l/min	850 l/min	1200 l/min
Min. water flow rate FM	–	1330 l/min	1330 l/min	–
Max. water flow rate	20000 l/min			
Operating temperature ³⁾	5° C – 50° C (standard version)			
	5° C – 80° C (High-Temp version) ⁴⁾			
Storage temperature	-20° C – 80° C			
Operating pressure	5 – 16 bar			
Weight ⁴⁾				
Freshwater version	506 kg	540 kg	780 kg	1010 kg
Seawater version ^{x)}	1071 kg	1105 kg	1350 kg	1580 kg
ATEX classification ^{x)} for +5 °C ≤ T _a ≤ +60 °C	 			

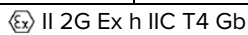
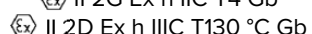
1) The nominal proportioning rate is achieved when reaching the specified minimum figure. Indication for proportioning of fluid Newtonian foam agents at operating pressure of 5 bar. For more detailed information, refer to page 2, item 3. “Minimum water flow rate”.

2) For information regarding FM Approved data, please refer to www.approvalguide.com.

3) Operating temp. is the max. ambient and medium (foam and extinguishing water) temperature. Max. foam agent temp. is generally limited to 50 °C.

4) Weight indications are based upon the standard version in dry condition. Special versions will differ.

X) Optional equipment.



Valid for selected product types.

www.firedos.com

■ 2. PRESSURE LOSS.

Indication valid for operating pressure of 10 bar. For more information on different system conditions or proportioning rates, please contact us.

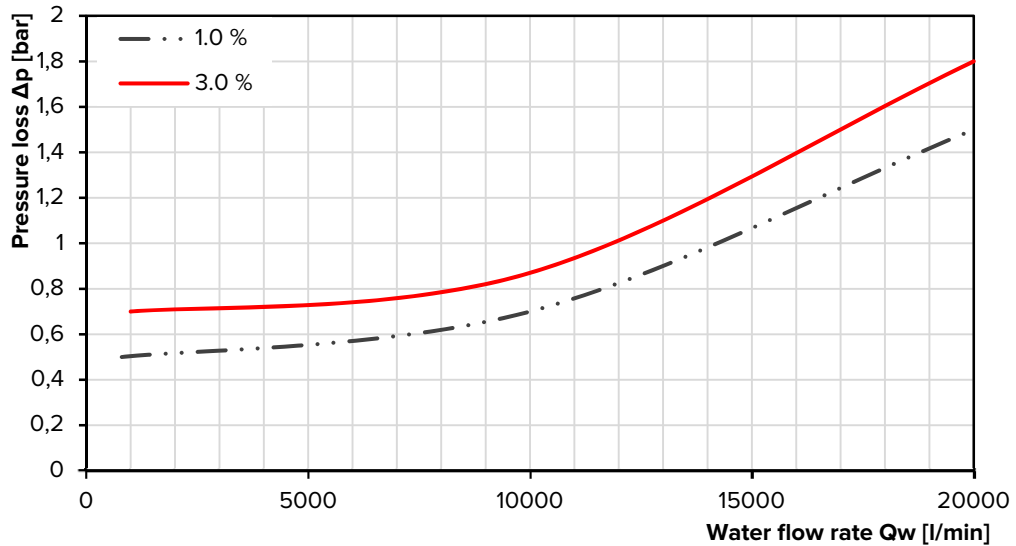

■ 3. MINIMUM WATER FLOW RATE.

The following diagrams show the effect of the operating pressure and foam agent viscosity on the minimum water flow rate (valid for viscosities in the graph at para. 4).

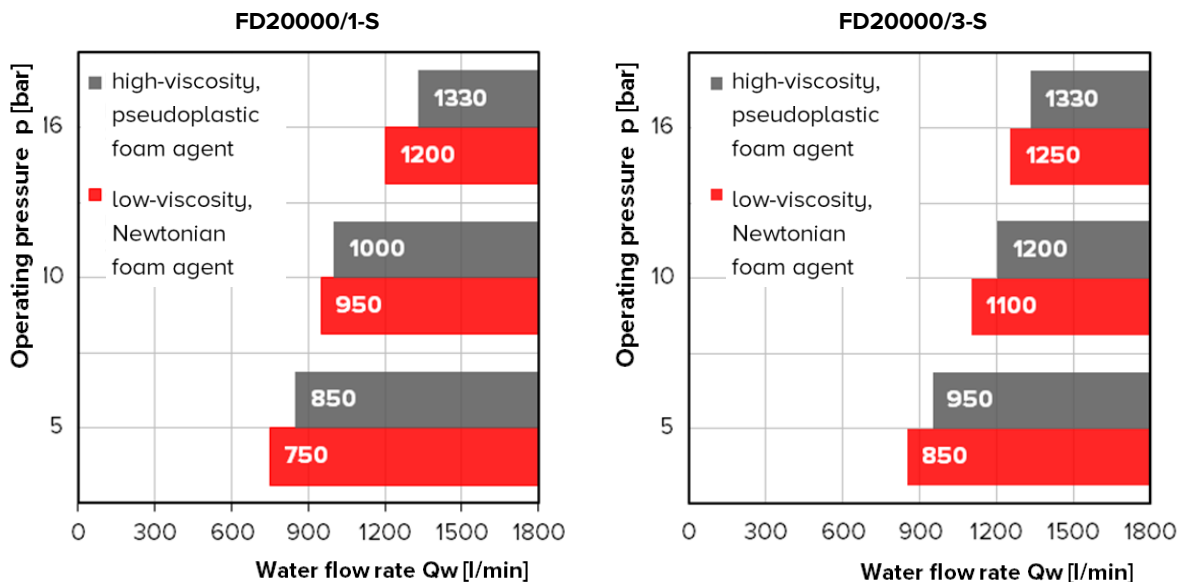

Comment:

The values can be reduced to approx. 35% by an optional flow reduction. The values increase by approx. 40% in the high-temp version. For values at other proportioning rates, please contact us.

4. FOAM AGENT VISCOSITY.

FireDos proportioners are suitable for all foam agents available on the market. For reference regarding units with an FM Approval, please find the corresponding/associated range of dynamic viscosity below (www.approvalguide.com). Contact us if the dynamic viscosity of your foam agent is higher than the values in the diagram. **Do not hesitate to request our support for the correct dimensioning of your suction line.**

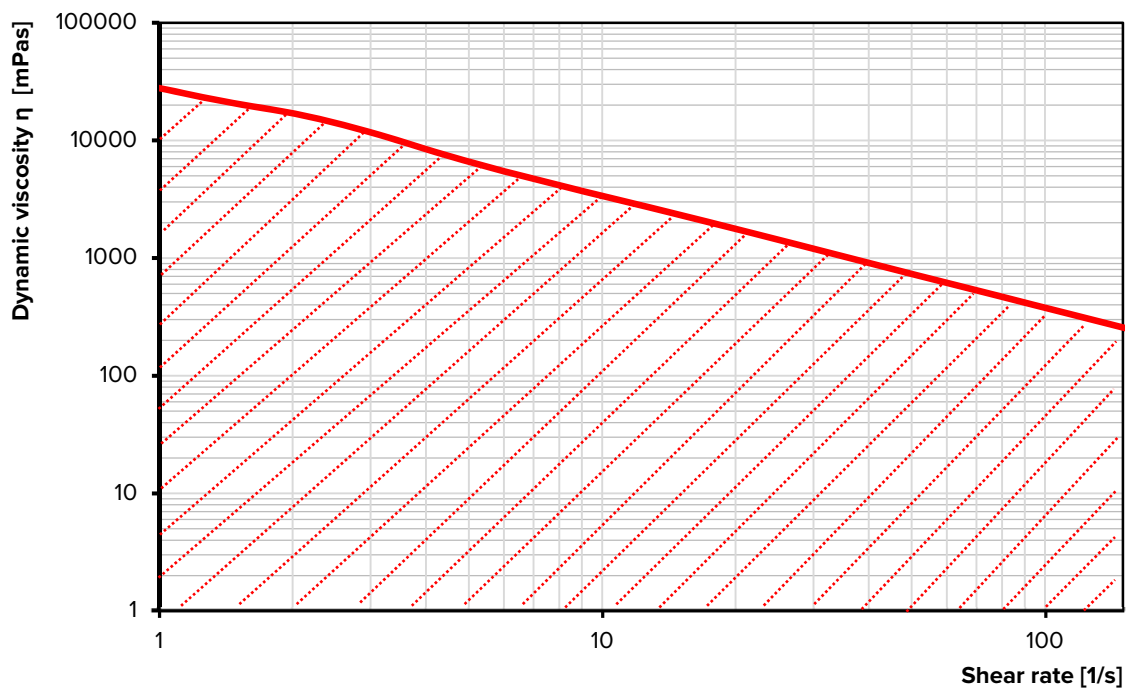

5. MATERIALS.

	Freshwater version	Seawater version
Water motor ⁴⁾	Cast Aluminium G-AlSi7Mg HC-coated, AlMgSi1 HC-PTFE-coated, stainless steel 316 / 316Ti, POM, PVDF, NBR, FKM	Cast Bronze G-CuSn10, stainless steel 316 / 316Ti, Aluminium-Bronze CuAl10Fe5Ni5-C-GC, POM, PVDF, NBR, FKM
Proportioning pump ⁴⁾	Stainless steel 316 / SS316Ti / 318 LN, POM, FKM, Aluminium oxide ceramic Al2O3, Aluminium-Bronze CuAl10Ni5Fe5-C-GC	
Pipework ⁴⁾	Stainless steel 316 / CF8M / SS316Ti, PTFE,	
Support frame	Stainless steel 304 / 316	

⁴⁾ media-exposed materials

■ 6. FLOW DIAGRAM.

Proportioning rate 0.5% / 1% / 3%

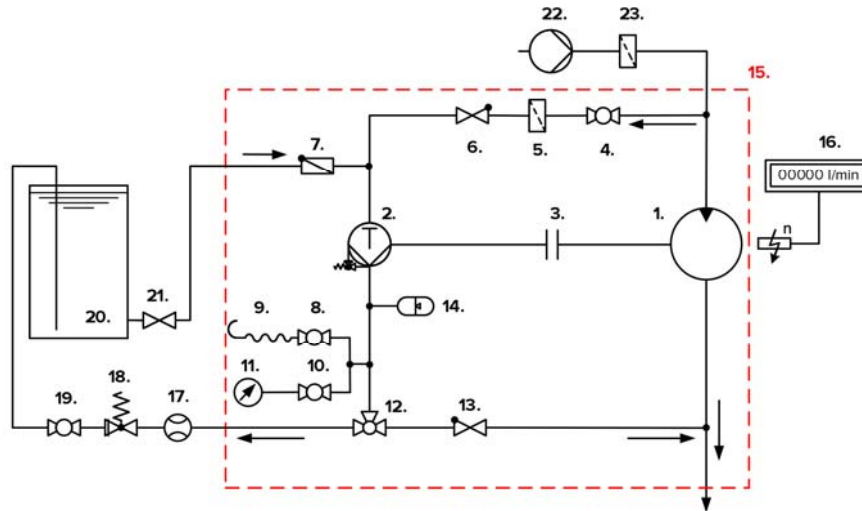

Proportioning rate 3% + 3% = 6%

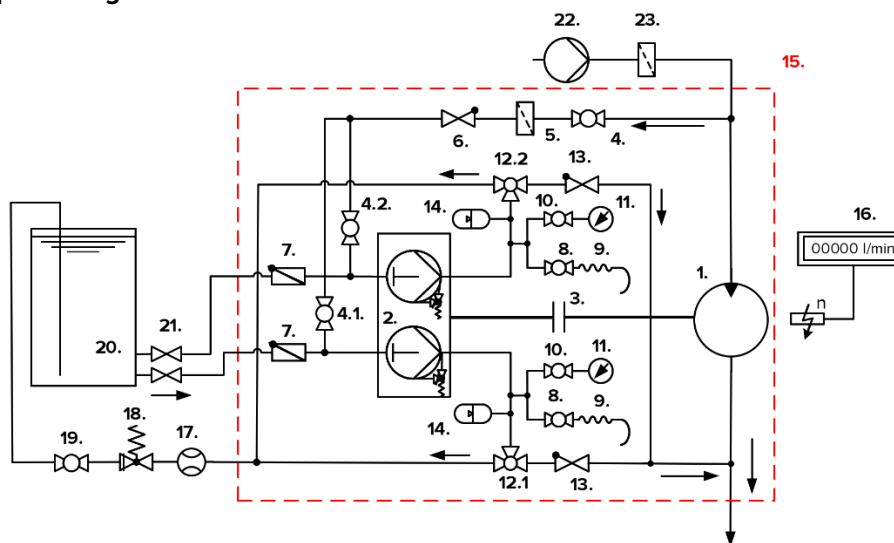

- | | |
|--|---|
| 1. Water motor | 12.1 "Returning/Proportioning" pump head I |
| 2. Proportioning pump | 12.2 "Returning/Proportioning" pump head II |
| 3. Coupling | 13. Check valve in the proportioning line |
| 4. 2-way ball valve "Flushing/Priming" | 14. Pulsation damper |
| 4.1 "Flushing/Priming" pump head I | 15. Standard scope of supply of FireDos proportioner |
| 4.2 "Flushing/Priming" pump head II | 16. Revolution counter with flow rate display ^{x)} |
| 5. Filter in the flushing line | 17. Flow meter for return line ^{x)} |
| 6. Check valve in the flushing line | 18. Pressure sustaining valve for return l ^{x)} |
| 7. Non-return flap in the suction line | 19. 2-way ball valve in return line ^{x)} |
| 8. Air bleed valve | 20. Foam agent supply |
| 9. Air bleed hose | 21. Shut-off valve in the suction line |
| 10. Shut-off valve pressure gauge | 22. Extinguishing water supply |
| 11. Pressure gauge | 23. Water filter |
| 12. 3-way ball valve "Returning/Proportioning" | |

X) Special version

7. EXAMPLE FIGURE / DIMENSIONS.

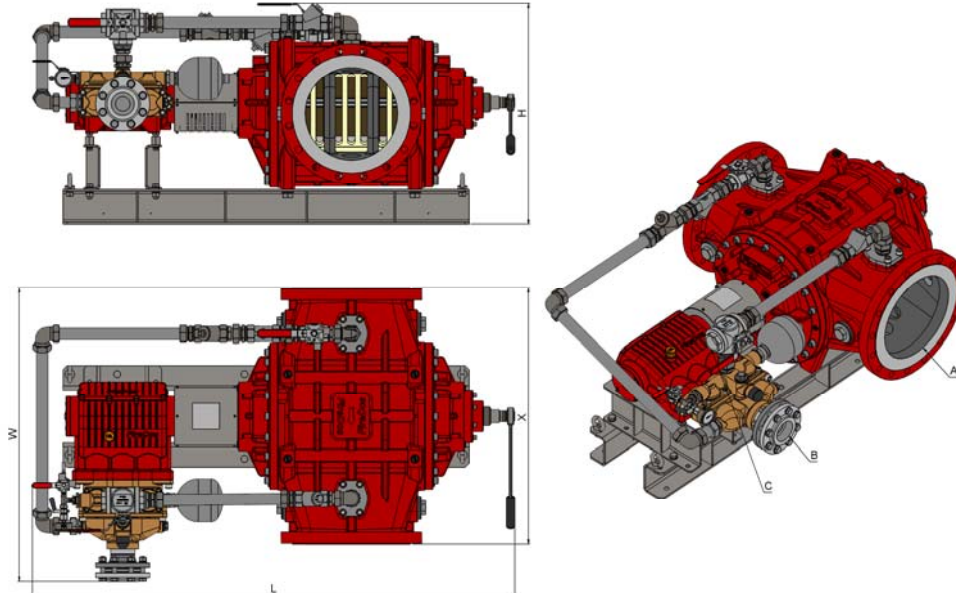

Type	FD20000/0,5-S	FD20000/1-S	FD20000/3-S	FD20000/3/3-S
Proportioning rate	0.5 %	1 %	3 %	3% + 3% = 6%
Connection water motor A	Optionally: Flange DIN EN 1092-1, DN350 PN16 RF Flange ASME B16.5, 14" Class 150 RF			
Installation length water motor X ⁵⁾	950 mm			
Connection suction line B	2.1/2" MT BSP Flange ASME B16.5 2.1/2" class 150 ^{X)}	3" FT BSP Flange ASME B16.5 3" Class 150 ^{X)}	5" FT BSP Flange ASME B16.5 6" Class 150 ^{X)}	2x 5" FT BSP 2x Flange ASME B16.5 6" Class 150 ^{X)}
Connection return line C	1.1/2" FT BSP 1.1/2" MT NPT ^{X)}	2" FT BSP 2" MT NPT ^{X)}	3" FT BSP Victaulic OGS DN65 ^{X)}	2x 3" FT BSP 2x Victaulic OGS DN65 ^{X)}
Length L ⁵⁾	1750 mm	1785 mm	1990 mm	2150 mm
Width W ⁵⁾	995 mm	1090 mm	1340 mm	1530 mm
Height H ⁵⁾	805 mm	820 mm	975 mm	1115 mm

All figures are approximate only and depend on the particular version/equipment options.

X) Special version.

5) Further accessories to the proportioner may require more installation space.

Please allow sufficient accessibility of the proportioner for maintenance work. For assistance to ensure sufficient accessibility, please refer to our planning manual for proportioners.

8. MANUFACTURER.

FireDos GmbH, Auf der Kaulbahn 6, 61200 Woelfersheim, Germany
Phone +49 (0) 6036 9796-0, Email: info@firedos.de

We reserve the right to make modifications at any time.