

Series 700DG-04C01

Piping & Instrumentation Diagram

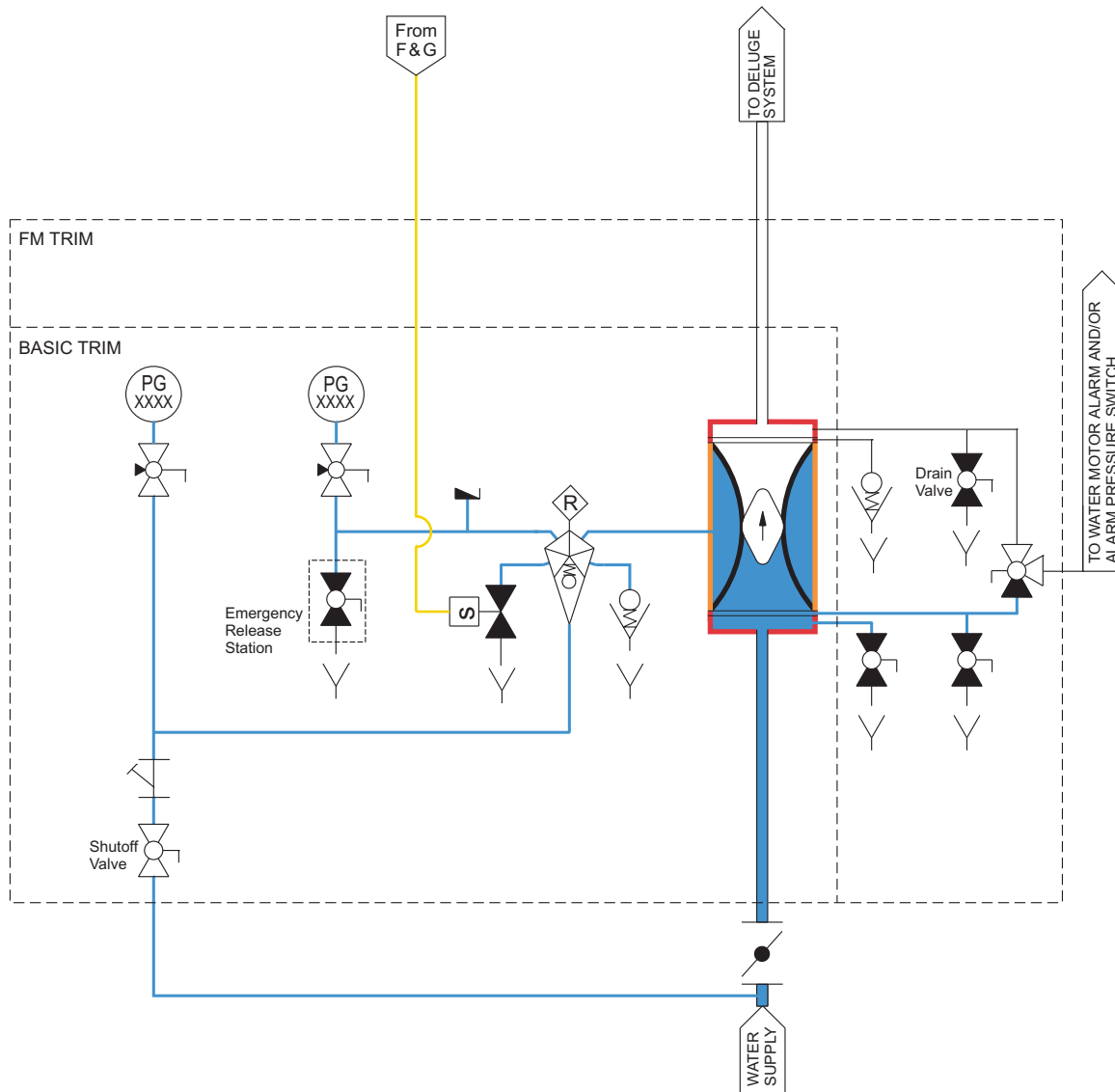

Inbal Deluge Valve, Electric Actuation, Local Resetting, Standard Material Control Trim



Inbal Automatic Water Control Valve (series 700DG)



Pressure Gauge (series 131)



Alarm Test Valve, 3-Way (series 347-08)



Pressure Gauge Valve (series 353)



Y-Strainer (series 31)



Ball Valve, 2-Way, N.O. (series 351)



Solenoid Valve, 2-Way N.C. (series 157)



Plug



Automatic Drain Valve (model 373-08)



Drain System

Water Line



Water Supply Valve



Flow Release Pilot (model 375-08)



Ball Valve, 2-Way, N.C. (series 351)

Electrical Line