

Series 700D-04B01

Piping & Instrumentation Diagram

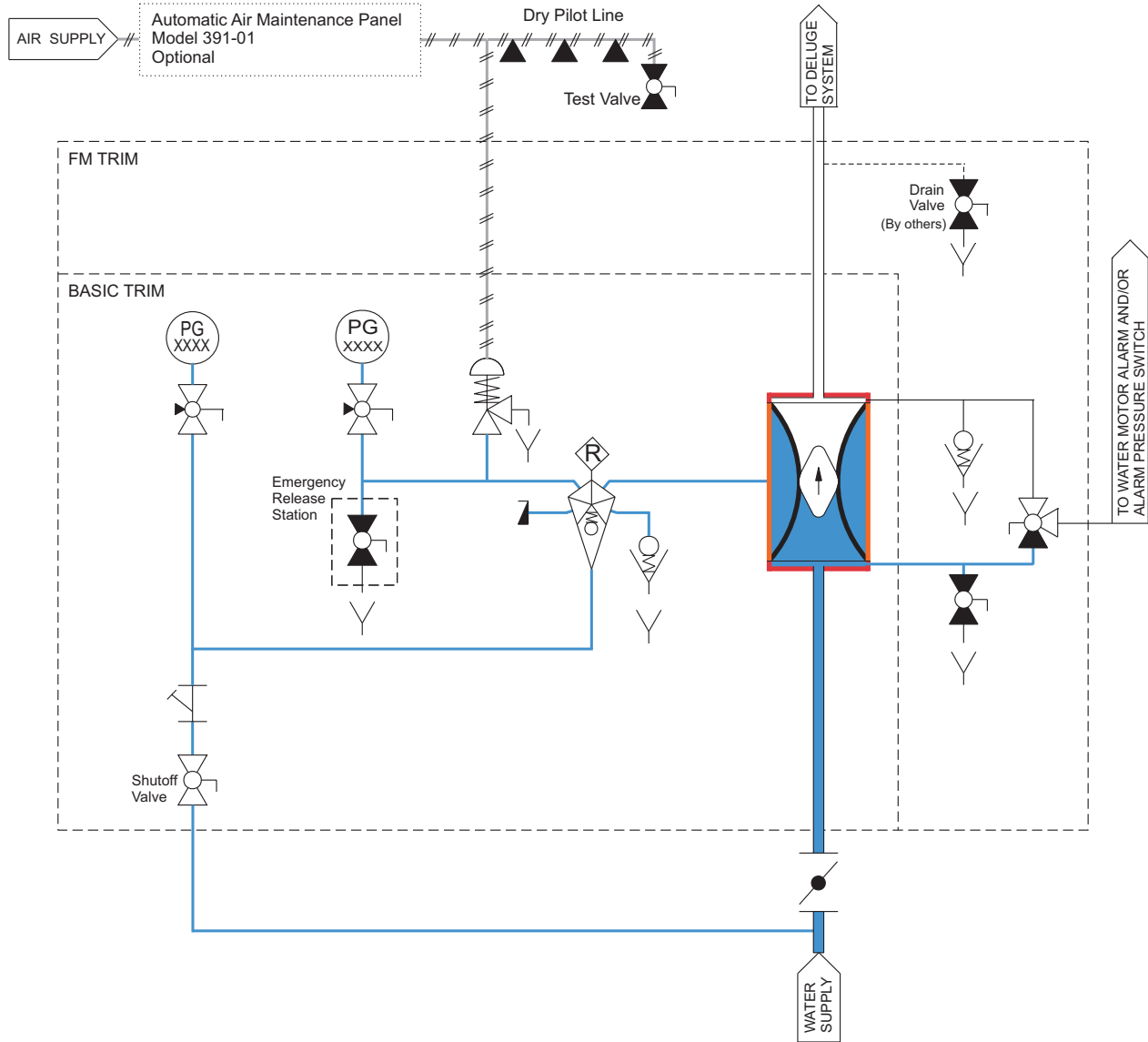

Inbal Deluge Valve, Pneumatic Actuation, Local Resetting, Standard Material Control Trim



Inbal Automatic Water Control Valve (series 700D)



Flow Release Pilot (model 375-08)



Pressure Gauge (series 131)



Plug



Pneumatic Actuator, 2-Way, N.O. (model 377-08)



Y- Strainer (series 31)



Check Valve (series 371)



Water Supply Valve



Ball Valve, 2-Way, N.O. (series 351)



Ball Valve, 2-Way, N.C. (Series 351)



Alarm Test Valve, 3-way (series 347-08)



Pressure Gauge Valve (series 353)



Automatic Drain Valve (model 373-08)



Fusible Sprinkler



Drain System

--- Air Line

— Water Line