

Model 711DX-04A01

FM Trim Overall Dimensions & Weights - Vertical Installation

Inbal Deluge Valve, Hydraulic Actuation, Local Resetting, Standard Material Control Trim



v a l v e s

FM Approved

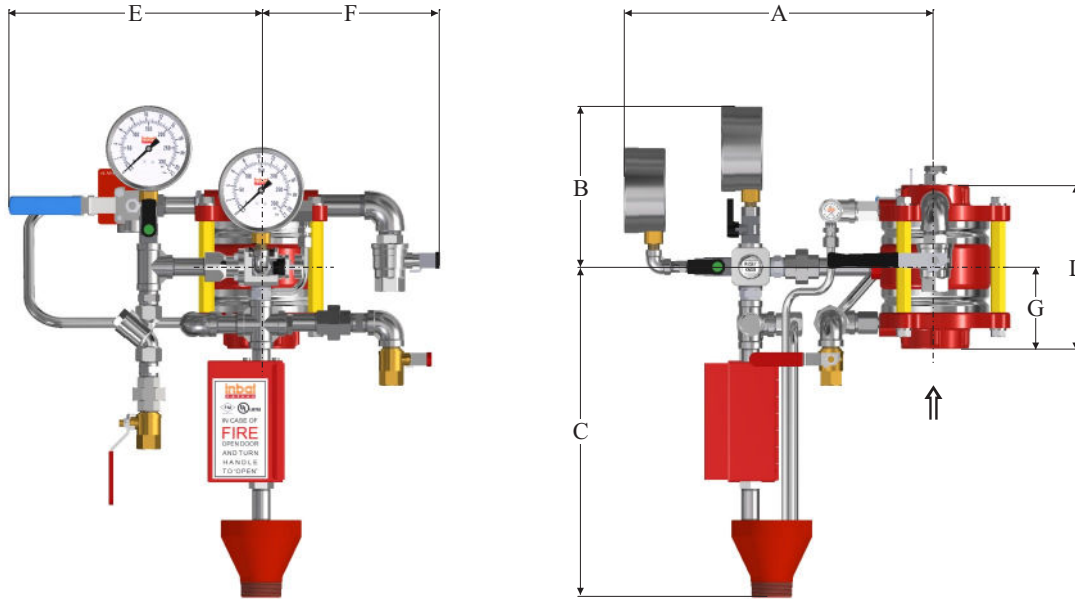

SIZE inches / mm	A	B	C	E	F	G	L	Weight* lbs / kg
1 ½	14 ¾	7 ⅞	15 ⅜	11 ½	9	3 ¾	7 ½	37.0 lbs
40	375	200	390	290	230	95	192	17.0 kg
2	14 ¾	7 ⅞	15 ⅜	11 ½	9	3 ¾	7 ½	37.0 lbs
50	375	200	390	290	230	95	192	17.0 kg
2 ½	14 ¾	7 ⅞	15 ⅜	11 ¾	10 ¼	3 ¾	8 ⅝	41.5 lbs
65	375	200	390	295	270	95	219	19.0 kg
3	14 ¾	7 ⅞	15 ⅜	13 ¾	10 ¼	4	8 ⅝	43.5 lbs
80	375	200	390	295	270	100	219	20.0 kg

* Refer to Standard Material Valve.

Model 711DX-04A01

FM Trim Chart - Vertical Installation

Inbal Deluge Valve, Hydraulic Actuation, Local Resetting, Standard Material Control Trim

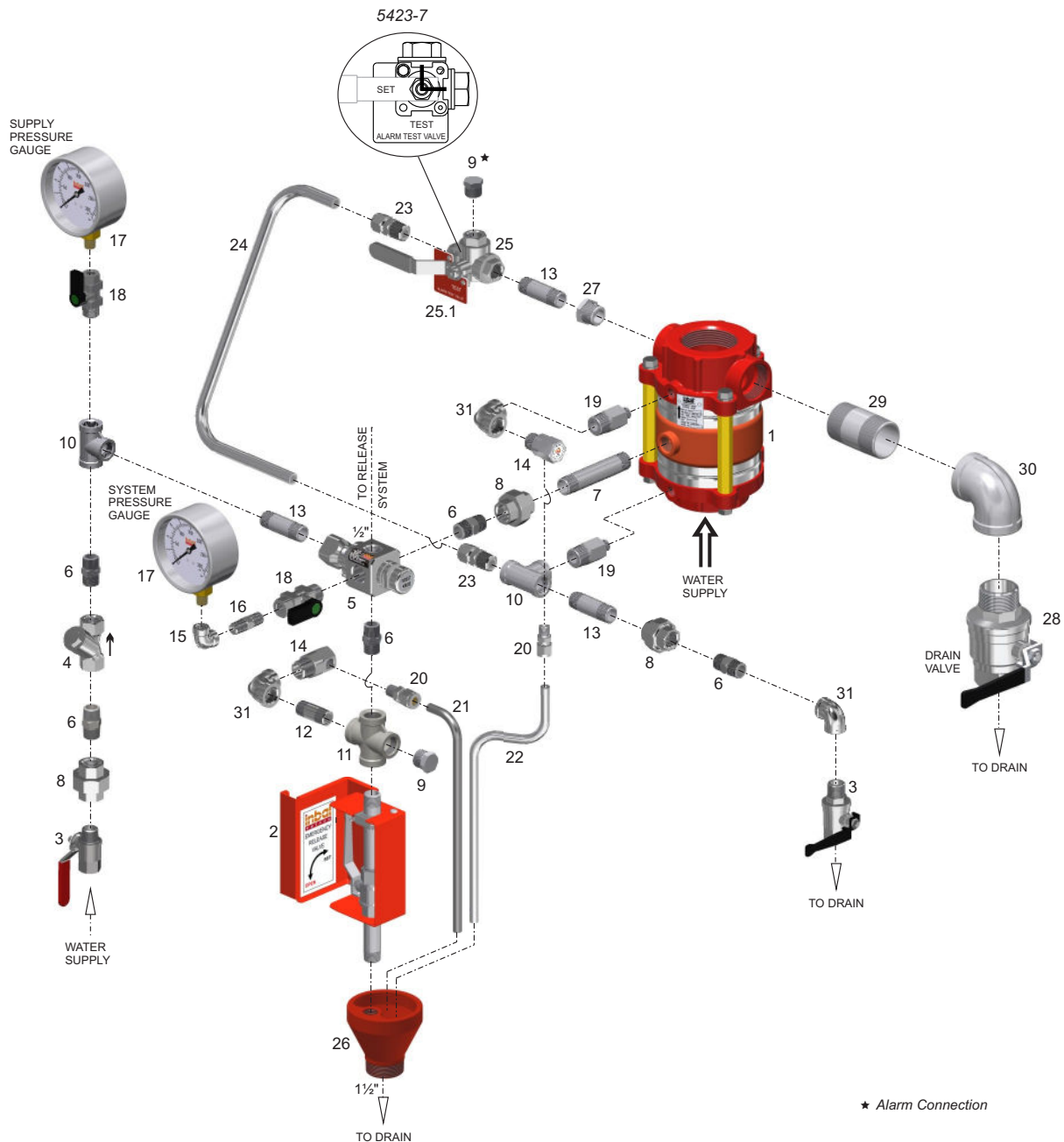

- The bill of materials is available in the next page.
- The alarm piping should be connected to the common port of the Alarm Test Valve. A Water Motor Alarm requires a 3/4" (20 mm) pipe. For an electric Alarm Pressure Switch - a 1/2" (15 mm) pipe can be used. When a Water Motor Alarm is used, a strainer is required.
- The control trim is supplied fully preassembled.
- When the control trim is ordered in loose components form, the Inbal Deluge Valve must be trimmed as shown. Any deviation may affect proper operation.

Model 711DX-04A01

FM Trim Chart - Vertical Installation



Inbal Deluge Valve, Hydraulic Actuation, Local Resetting, Standard Material Control Trim

Item	Description	Qty	Material	Cat. No.
1	Inbal Automatic Water Control Valve model 711DX	1	See bulletin F02-03	1711DX01DDSSSS
2	Emergency Release Station model 393-01	1	See bulletin F34-04	239302001002
3	2-Way Ball Valve 1/2", series 351	2	See bulletin F40-08	235102008000
4	Y-Pattern Strainer 1/2", series 31	1	See bulletin F40-03	231006008001
5	F.R.P. model 375-08	1	See bulletin F33-01	137502008000
6	Hex. Nipple 1/2"	5	St.St.304	212206008001
7	Nipple 1/2", L=3 1/2" (89 mm)	1	St.St.304	212206032000
8	Union 1/2" F x F	3	St.St.304	210406008000
9	Plug 1/2"	2	St.St.304	212106008000
10	Tee 1/2"	2	St.St.304	210106008001
11	Cross 1/2"	1	St.St.304	211106008001
12	Nipple 1/2", L=2" (50 mm)	1	St.St.304	212206003000
13	Nipple 1/2", L=2 1/2" (63 mm)	3	St.St.304	212206016001
14	Automatic Drain Valve model 373-08	2	See bulletin F40-13	137302008000
15	Elbow 1/4"	1	St.St.304	210006004001
16	Hex. Nipple 1/4" L= 1 1/16" (43 mm)	1	St.St.304	212206004003
17	Pressure Gauge	2	See bulletin F40-15	213106041002
18	Pressure Gauge Valve 1/2" x 1/4"	2	See bulletin F40-09	235302008001
19	Red. Nipple 1/2" x 1/4", L=2" (51 mm)	2	St.St.304	212306012001
20	Tube Fitting 1/4"NPT x 3/8" OD	2	Brass, Ni-Cr plated	314002003000
21	Drain Tube 3/8" OD	1	St.St.316	994006060000
22	Drain Tube 3/8" OD	1	St.St.316	994006060000
23	Twin Ferrules Fitting 1/2" NPT x 1/2" OD	2	Brass, Ni-Cr plated	318902007000
24	Alarm Test Tube 1/2" OD	1	St.St.316	994006008000
25	Alarm Test Valve model 347-08-02	1	See bulletin F40-06	234706008000
25.1	Label	1	PVC	
26	Drain Cup	1	Steel, Epoxy coated	397000000000
27	Bushing 3/4"M x 1/2"F	1	See note (a)	211006002001
28 (b)	2-Way Ball Valve 3/4", series 351	1	See bulletin F40-08	235102020000
(c)	2-Way Ball Valve 1 1/2", series 351	1	See bulletin F40-08	235102040000
29 (b)	Nipple 3/4", L=3" (80 mm)	1	St.St.304	212206010001
(c)	Nipple 1 1/2", L=3 1/4" (83 mm)	1	St.St.304	212206001000
30 (b)	Elbow 3/4"	1	See note (a)	210006012001
(c)	Elbow 1 1/2"	1	See note (a)	210006024001
31	Elbow 1/2"	2	St.St.304	210006008001

Notes: (a) Brass, Ni-Cr plated or Stainless Steel AISI 304.
 (b) For 1 1/2" & 2" (40 & 50 mm) Inbal Valves.
 (c) For 2 1/2" & 3" (65 & 80 mm) Inbal Valves.