

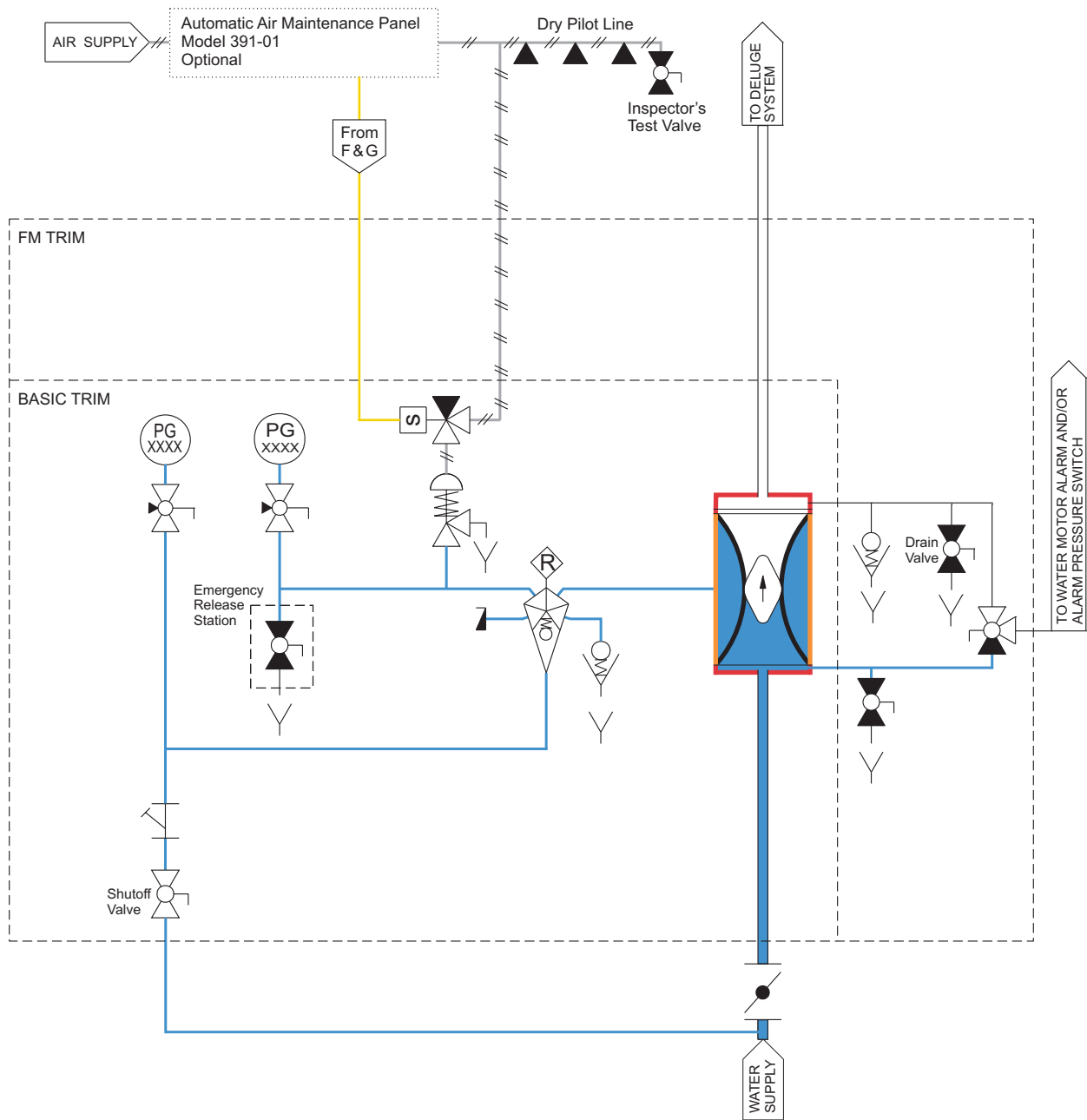

















Series 700DX-04D01

Piping & Instrumentation Diagram



Inbal Deluge Valve, Pneu-Electric Actuation, Local Resetting, Standard Material Control Trim



	Inbal Automatic Water Control Valve (series 700DX)		Pneumatic Actuator, 2-Way, N.O. (model 377-08)		Ball Valve, 2-Way, N.O. (series 351)		Automatic Drain Valve (model 373-08)
	Flow Release Pilot (model 375-08)		Y-Strainer (series 31)		Ball Valve, 2-Way, N.C. (Series 351)		Fusible Sprinkler
	Pressure Gauge (series 131)		Water Supply Valve		Alarm Test Valve, 3-way (series 347-08)		Drain System
	Plug		Solenoid Valve, 3-Way N.O. (series 151,153)		Pressure Gauge Valve (series 353)		Electrical Line
							Air Line
							Water Line