

Series 700D-01S03

Piping & Instrumentation Diagram

Inbal Pressure Relief Valve, Standard Material Control Trim

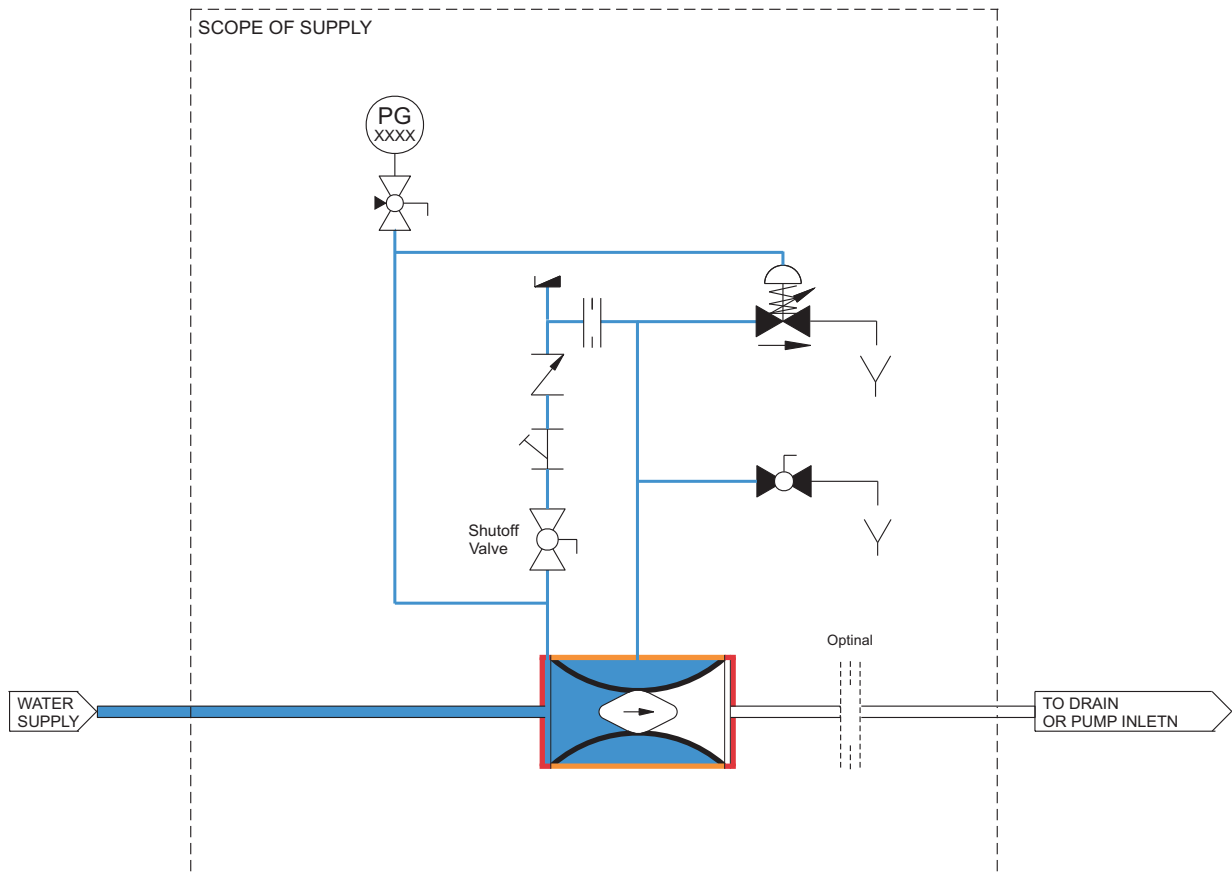

Inbal Automatic Water Control Valve (series 700D)



Ball Valve, 2-Way, N.O. (series 351)



Ball Valve, 2-Way, N.C. (series 351)



Pressure Sustaining Pilot Valve, Adjustable, 2-Way, N.C. (model PA2/PB2)



Pressure Gauge (series 131)



Check Valve (series 371)



Restriction Orifice/Orifice Plate



Drain System



Plug



Y-Strainer (series 31)



Pressure Gauge Valve (series 353)

Water Line