

Model 799DX-04G01-B



Full Trim Overall Dimensions & Weights - Vertical Installation

v a l v e s

Inbal Preaction Valve, Non Interlock, Electric Actuation, Local Resetting, Standard Material Control Trim, with Accelerator

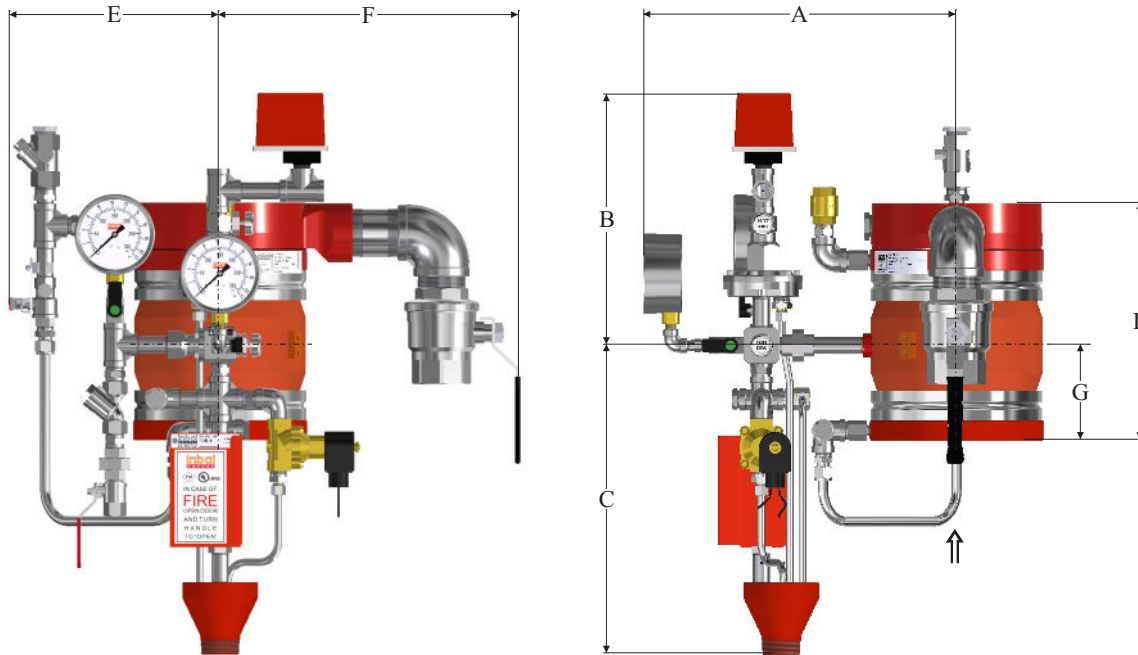

SIZE inches / mm	A	B	C	E	F	G	L	Weight* lbs / kg
3	14 ¾	15	15 ⅜	8 ⅞	13 ¼	3 ¼	8 ⅞	63.0 lbs
80	375	380	390	225	335	80	207	29.0 kg
4	15 ¼	15	15 ⅜	9 ½	14 ½	3 ¾	10 ⅞	80.5 lbs
100	388	380	390	240	365	95	257	37.0 kg
6	16 ½	15	15 ⅜	10 ⅝	15	4 ¾	11 ¾	107.0 lbs
150	418	380	390	270	375	120	298	49.0 kg
8	17 ⅝	15	15 ⅜	11 ¾	15 ¾	6	14 ¼	152.5 lbs
200	447	380	390	300	400	155	362	70.0 kg
10	18 ½	15	15 ⅜	12 ¾	18 ¼	7	16 ⅞	203.0 lbs
250	472	380	390	325	460	175	410	93.0 kg
12	19 ¼	15	15 ⅜	13 ¾	19 ¼	8 ¾	19 ⅞	266.0 lbs
300	488	380	390	350	490	225	503	122.0 kg

* Refer to Standard Material Valve.

Model 799DX-04G01-B

Full Trim Chart - Vertical Installation



Inbal Preaction Valve, Non Interlock, Electric Actuation, Local Resetting, Standard Material Control Trim, with Accelerator

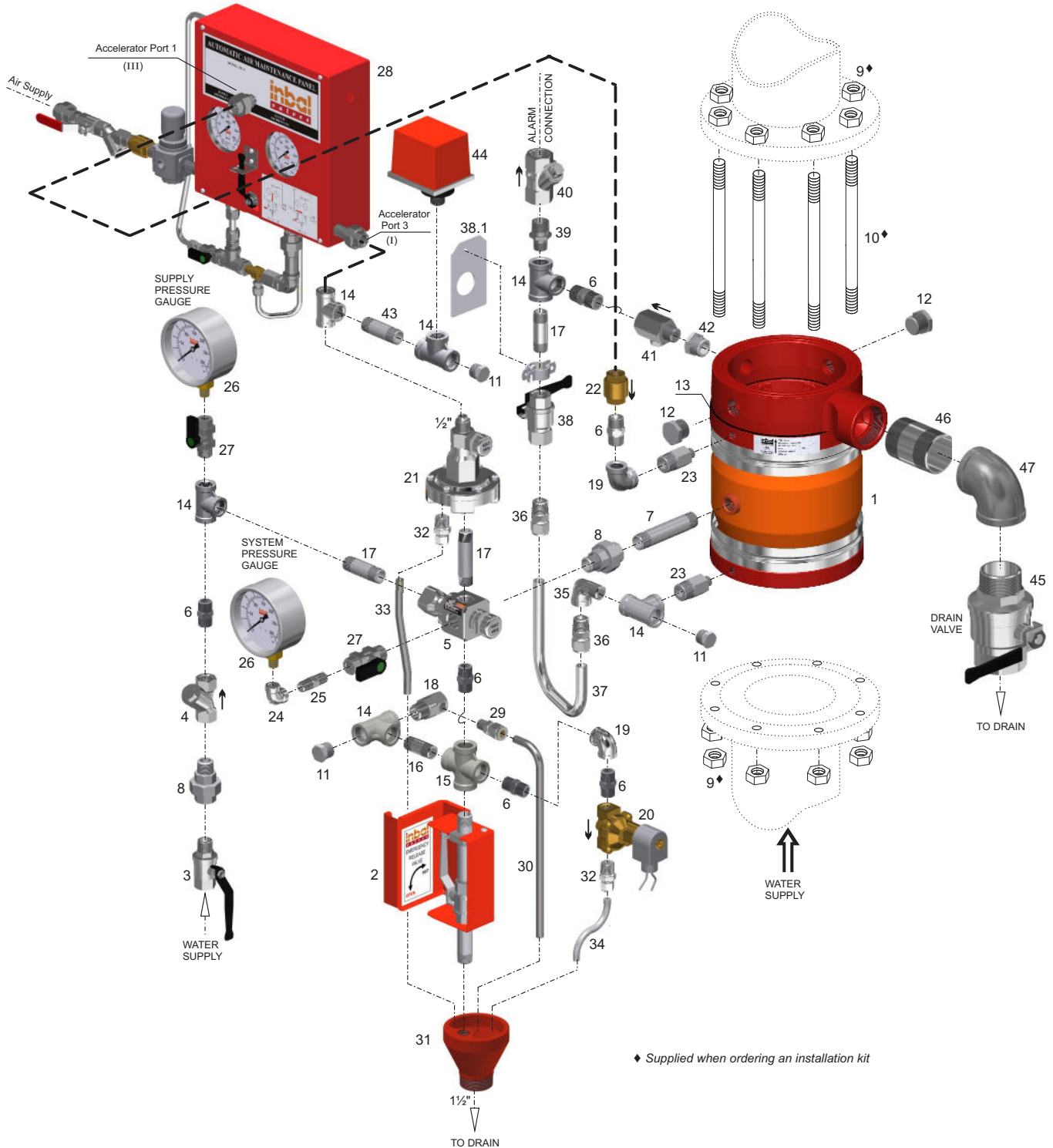

- The bill of materials is available in the next page.
- The alarm piping should be connected to the common port of the Alarm Test Valve. A Water Motor Alarm requires a 3/4" (20 mm) pipe. For an electric Alarm Pressure Switch - a 1/2" (15 mm) pipe can be used. When a Water Motor Alarm is used, a strainer is required.
- The control trim is supplied fully preassembled.
- When the control trim is ordered in loose components form, the Inbal Preaction Valve must be trimmed as shown. Any deviation may affect proper operation.

Model 799DX-04G01-B

Full Trim Chart - Vertical Installation



Inbal Preaction Valve, Non Interlock, Electric Actuation, Local Resetting, Standard Material Control Trim, with Accelerator

Item	Description	Qty	Material	Cat. No.
1	Inbal Automatic Water Control Valve model 799DX	1	See bulletin F02-03	1799DX01DDSSSS
2	Emergency Release Station model 393-01	1	See bulletin F34-04	239302001002
3	2-Way Ball Valve 1/2", series 351	1	See bulletin F40-08	235102008000
4	Y-Pattern Strainer 1/2", series 31	1	See bulletin F40-03	231006008001
5	F.R.P. model 375-08	1	See bulletin F33-01	137502008000
6	Hex. Nipple 1/2"	6	St.St.304	212206008001
7	Nipple 1/2", L=4" (102 mm)	1	St.St.304	212206018001
8	Union 1/2" M x F	2	St.St.304	210406008006
9	Nut	(a)	Galvanized Steel	22420101DDDD
10	Stud Bolt	(a)	Galvanized Steel	226001RRRRRR
11	Plug 1/2"	3	St.St.304	212106008000
12	Plug 3/4"	2	See note (b)	212106012000
13	Gasket. Thickness: 1/16" (1.6 mm)	1	Fiber	270709DDDD000
14	Tee 1/2"	6	St.St.304	210106008001
15	Cross 1/2"	1	St.St.304	211106008001
16	Nipple 1/2", L=2" (50 mm)	1	St.St.304	212206003000
17	Nipple 1/2", L=2 1/2" (63 mm)	3	St.St.304	212206016001
18	Automatic Drain Valve model 373-08	1	See bulletin F40-13	137302008000
19	Elbow 1/2"	2	St.St.304	210006008001
20	Solenoid Valve series 157	1		
21	Pneumatic Actuator model 379-08	1	See bulletin F32-02	137902008000
22	Check Valve 1/2", series 371	1	See bulletin F40-12	137102008000
23	Red. Nipple 1/2" x 1/4", L=2" (51 mm)	2	St.St.304	212306012001
24	Elbow 1/4"	1	St.St.304	210006004001
25	Hex. Nipple 1/4" L=1 1/16" (43 mm)	1	St.St.304	212206004003
26	Pressure Gauge	2	See bulletin F40-15	213106041002
27	Pressure Gauge Valve 1/2" x 1/4"	2	See bulletin F40-09	235302008001
28	Automatic Air Maintenance Panel with Accelerator model 391-05	1	see bulletin F34-07	
29	Tube Fitting 1/4" NPT x 3/8" OD	1	Brass, Ni-Cr plated	314002003000
30	Drain Tube 3/8" OD	1	St.St.316	994006060000
31	Drain Cup	1	Steel, Epoxy coated	397000000000
32	Tube Fitting 1/2" NPT x 3/8" OD	2	Brass, Ni-Cr plated	314002007000
33	Drain Tube 3/8" OD	1	St.St.316	994006060000
34	Drain Tube 3/8" OD	1	St.St.316	994006060000
35	Street Elbow 1/2"	1	St.St.304	211606008001
36	Twin Ferrules Fitting 1/2" NPT x 1/2" OD	2	Brass, Ni-Cr plated	318902007000
37	Alarm Test Tube 1/2" OD	1	St.St.316	994006008000
38	Alarm Test Valve model 351-08-01, (FxF)	1	See bulletin F40-08	
38.1	Label	1	P.V.C.	
39	Red. Nipple 3/4" x 1/2"	1	St.St.304	212306008000
40	Check Valve 3/4", 371-12-01	1	Brass	137102012001
41	Check Valve 1/2", series 371	1	See bulletin F40-12	137102008000
42	Bushing 3/4" M x 1/2" F	1	See note (b)	211006002001
43	Nipple 1/2", L=3" (76 mm)	1	St.St.304	212206005000
44	Pressure Switch series 161-03	1	See bulletin F31-01	216100003000
45 (c)	2-Way Ball Valve 1 1/2", series 351	1	See bulletin F40-08	235102040000
(d)	2-Way Ball Valve 2", series 351	1	See bulletin F40-08	235102050000
46 (c)	Nipple 1 1/2", L=3 1/4" (83 mm)	1	St.St.304	212206001000
(d)	Nipple 2", L=3 1/4" (83 mm)	1	St.St.304	212206009001
47 (c)	Elbow 1 1/2"	1	See note (b)	210006024001
(d)	Elbow 2"	1	See note (b)	210006032001

Notes: (a) Supplied when ordering an installation kit. Quantity and thread standard for Stud Bolts and Nuts may vary, depending on Inbal Valve size and flange standard.
(b) Brass, Ni-Cr plated or Stainless Steel AISI 304.

(c) For 3" (80 mm) Inbal Valves.
(d) For 4", 6", 8", 10" & 12" (100; 150; 200; 250 & 300 mm) Inbal Valves.