

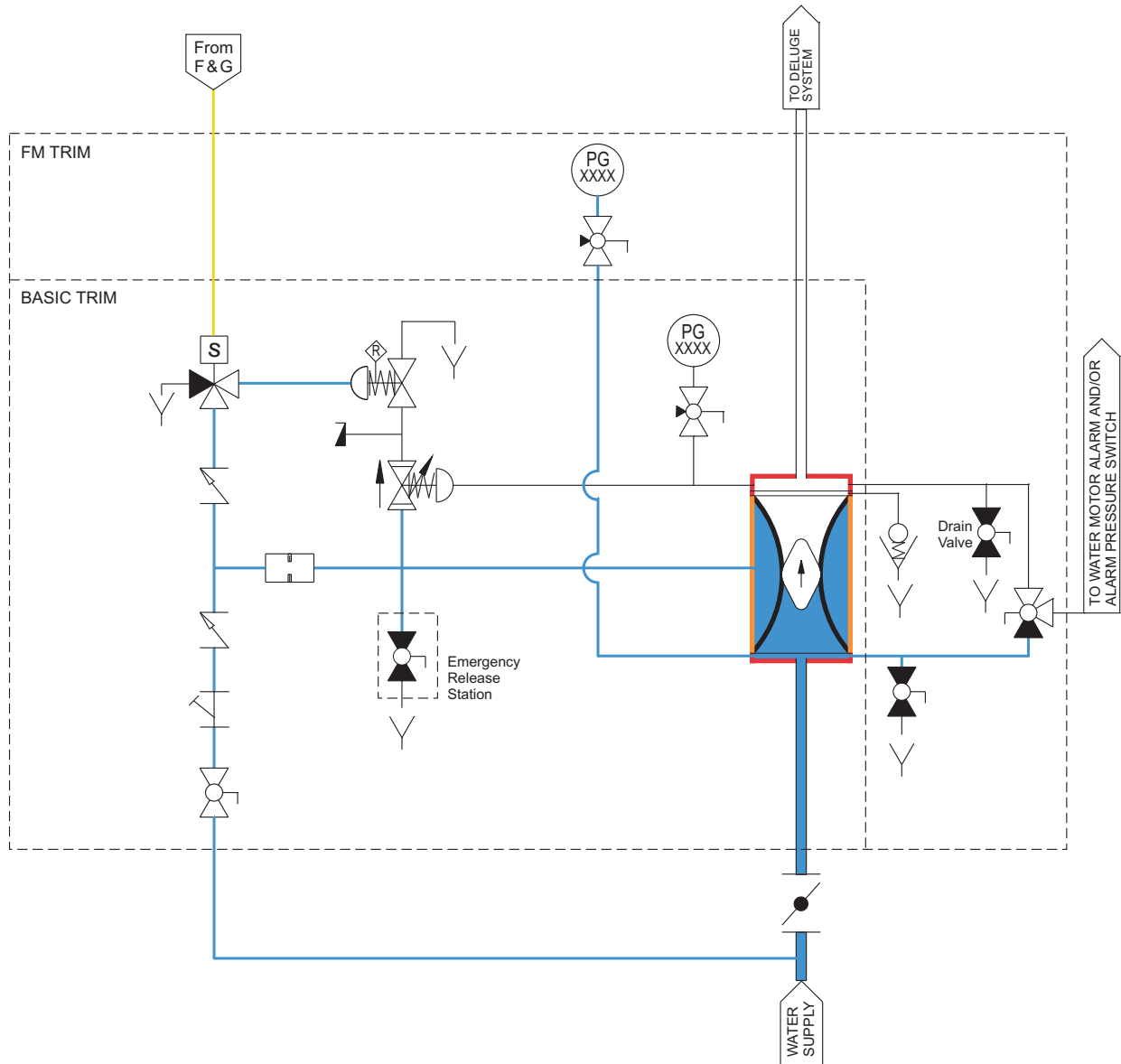

















Series 700DX-04CR05

Piping & Instrumentation Diagram



Inbal Deluge Valve, Pressure Control, Electric Actuation, Local Resetting, Standard Material Control Trim



 Inbal Automatic Water Control Valve (series 700DX)	 Ball Valve, 2-Way, N.O. (series 351)	 Pressure Gauge (series 131)	 Pressure Gauge Valve (series 353)
 Flow Control Unit	 Ball Valve, 2-Way, N.C. (series 351)	 Automatic Drain Valve (model 373-08)	 Plug
 Check Valve (series 371)	 Alarm Test Valve, 3-Way (series 347-08)	 Deluge Pilot Valve, 2-Way, N.O. (series 290)	 Drain System
 Water Supply Valve	 Solenoid Valve, 3-Way N.O. (S)	 Pressure Reducing Pilot Valve (model PA1/PB1)	 Electrical Line
 Y-Strainer (series 31)			 Water Line