

# Series 700DX-03C06

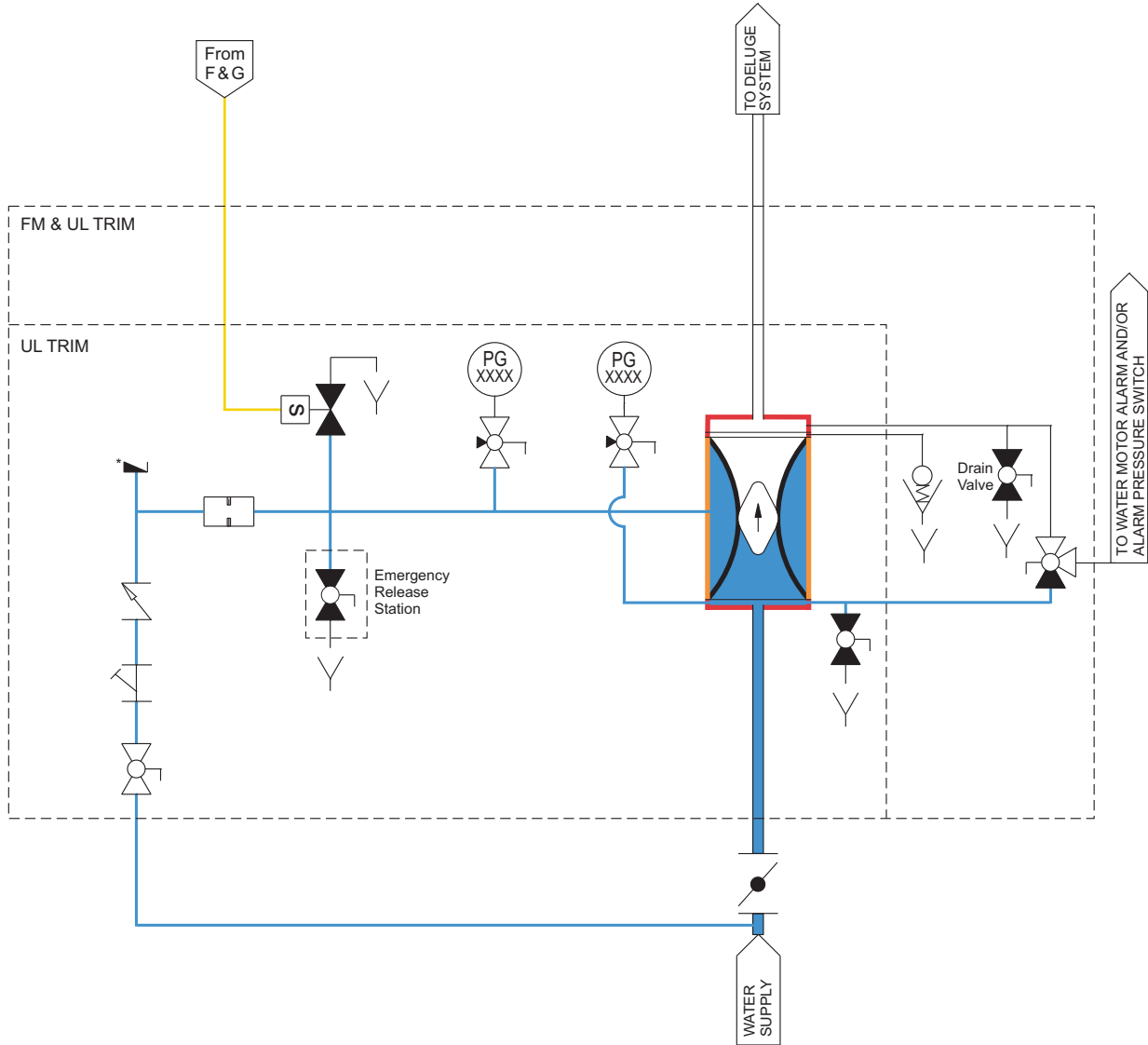















## Piping & Instrumentation Diagram



Inbal Deluge Valve, Electric Actuation, Remote Resetting, Standard Material Control Trim



\* Optional connection for Additional Systems

	<b>Inbal Automatic Water Control Valve</b> (series 700DX)		Ball Valve, 2-Way, N.O. (series 351)		Pressure Gauge (series 131)		Water Supply Valve
	Flow Control Unit		Ball Valve, 2-Way, N.C. (series 351)		Automatic Drain Valve (model 373-08)		Electrical Line
	Check Valve (series 371)		Alarm Test Valve, 3-Way (series 347-08)		Solenoid Valve, 2-Way N.C.		Drain System
	Y- Strainer (series 31)		Pressure Gauge Valve (series 353)		Plug		Water Line